

Tetra® Power White XL

LED Lighting System

(GEWHXHS2-65K, GEWWXHS2-32K, GEWWXHS3-32K)

Tools and Components Required

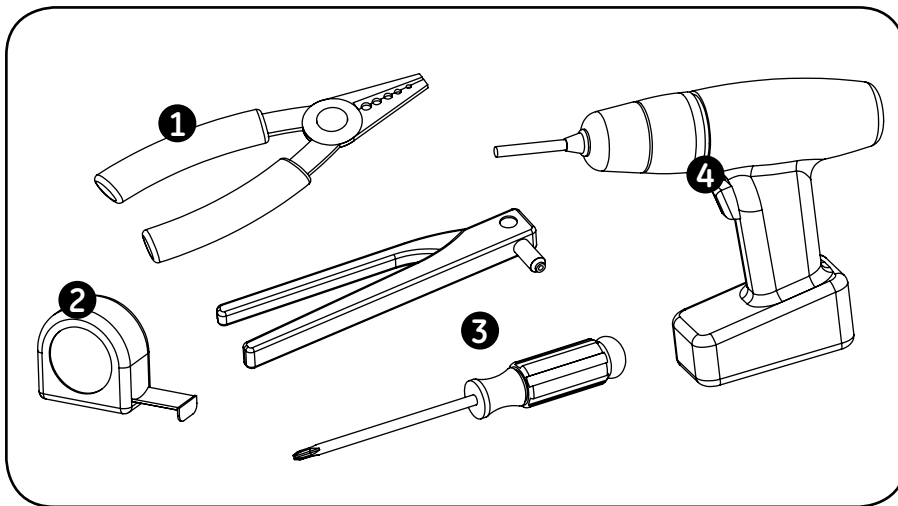

Tools required:

- 1 Wire stripper/cutter
- 2 Tape measure
- 3 Rivet gun or screwdriver
- 4 Cordless drill

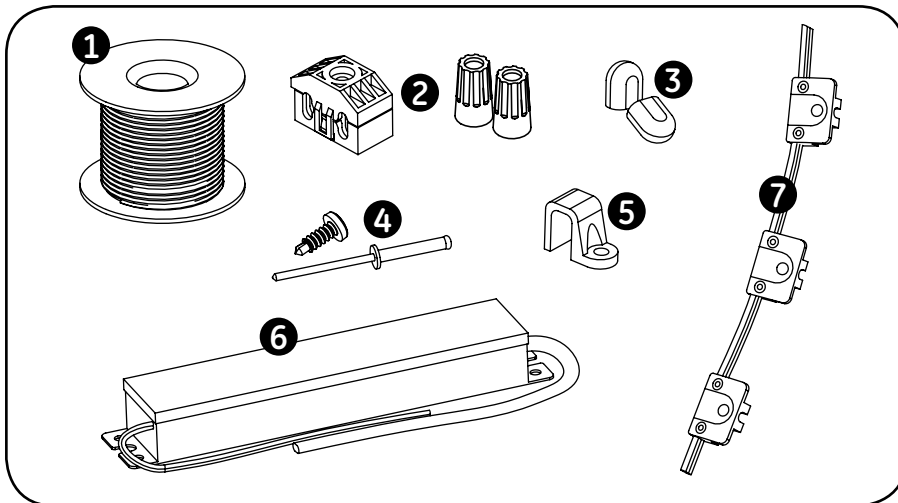

Components required:

- 1 UL approved 14 AWG (2.08mm²) supply wire
- 2 UL approved 22-14 AWG twist-on wire connectors (0.33 - 2.08 mm²) or splice connectors
- 3 End caps
- 4 #6 (M3) self-drilling pan headed screws or 1/8-inch (3mm) rivets
- 5 Wire clips
- 6 Power Supply
- 7 Tetra® Power White XL Modules



imagination at work

⚠ WARNING

Risk of electrical shock. Turn power OFF before inspection, installation or removal.

Layout Modules

Carefully remove all neon tubing, tube supports and transformers. Make sure the removal of neon equipment does not compromise the integrity of the sign body (i.e. water intrusion). Fill in all holes 0.5-inch (13mm) or smaller with the appropriate amount of rated caulk or silicone. For holes greater than 0.5-inch (13mm), use an aluminum or zinc coated steel patch with rivets and caulk to insure that the integrity of the letter is not compromised.

NOTE: We recommend the use of light enhancing paint or light enhancing film on the inside of the channel letter to increase face intensity up to 30%.

NOTE: For CUL Canadian coverage, a disconnect switch is required for the Canadian electrical code. Refer to the power supply installation instructions for disconnect switch details.

NOTE: Follow all federal and local regulations when disposing of neon tubing and transformers.

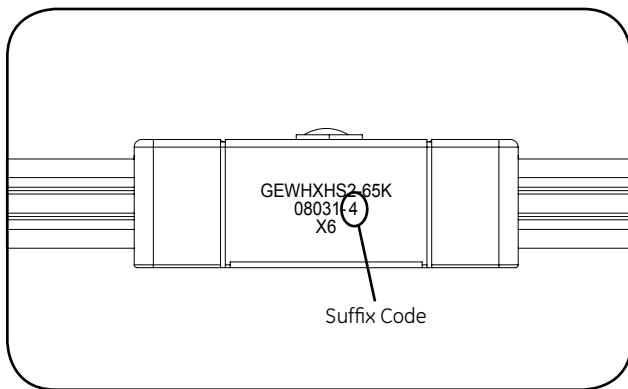

- 1 Locate suffix code on product or packaging. The suffix code is located on the packaging in a single-digit label. The suffix code is also located on each module as the last digit on the center set of numbers (i.e. 4, 5 or 6, etc.). Do not use more than one suffix code per application. Mixing suffix codes may result in appearance variation.

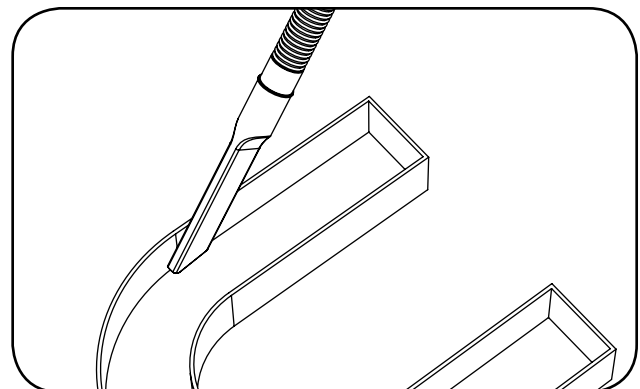

- 2 Clean & remove all debris from the inside of the channel letter before you begin.

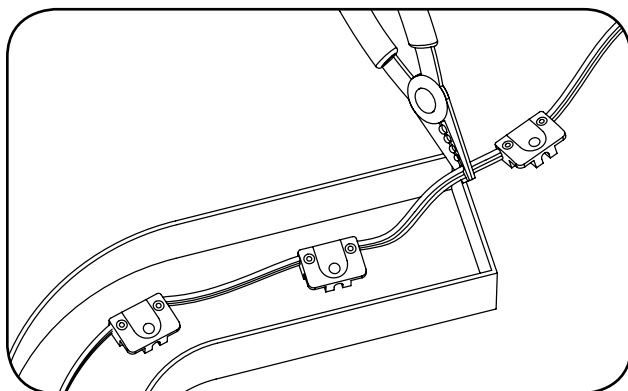

- 3 Measure and cut Tetra Power White XL to the appropriate length for each letter.

NOTE: Cut Tetra Power White XL strip only at the "Cut Here" markings on the wire.

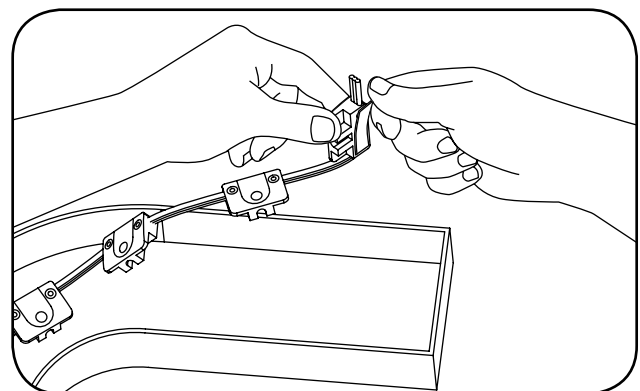

- 4 Remove tape backing and stick LED modules into place. Continue until you have reached the end of the strip.

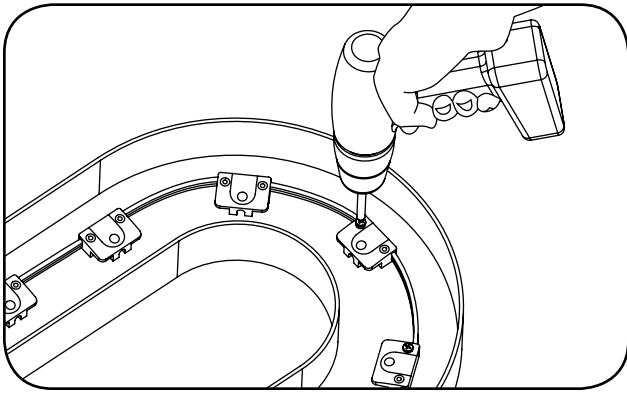

- 5** Rivets or screws **MUST BE** used to secure the LED strip within the channel letter. Use #6 (M3) self-drilling pan headed screws or 1/8-inch (3mm) rivets.

Wire clips (GECLWM1) can also be used for additional reinforcement.

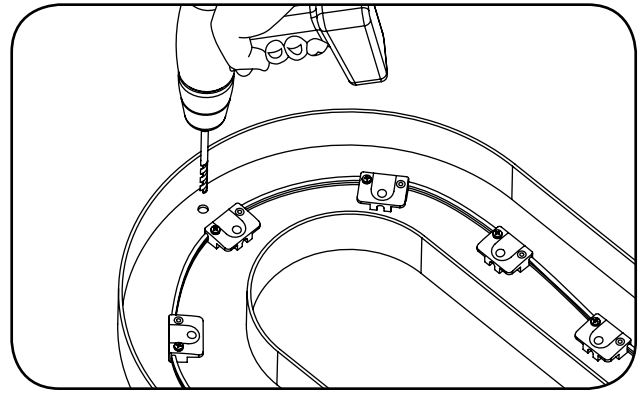

- 6** Drill a hole near the center of the Tetra Power White XL Strip for the power supply wires to pass thru. Grommet the hole.

Electrical Connections

Measure the amount of supply wire needed to reach the power supply from the farthest letter.

NOTE: Recommended distance from power supply to Tetra Power White XL Strip is up to 20 ft. (6.1m).

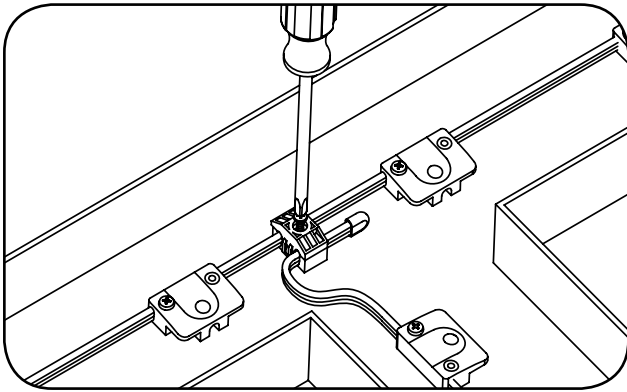

- 1** Connect Tetra Power White XL Strips using splice connectors or twist-on wire connectors. Verify connections are blue to blue and white to white.

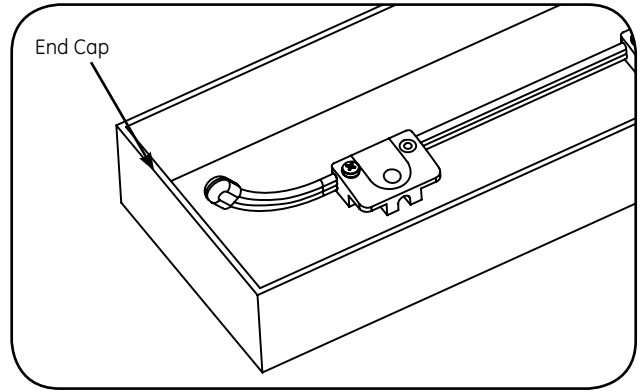

- 2** All unused wires **MUST BE** capped with GECLEC1 end caps or apply electronics grade silicone for additional weather protection.

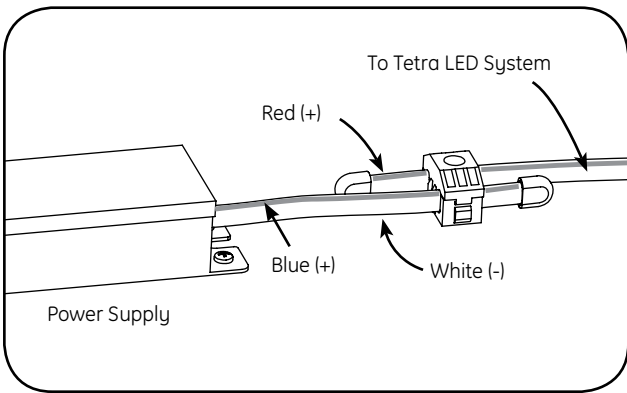

- 3** Run a supply wire (GECLSW1) from the Power Supply to each channel letter.

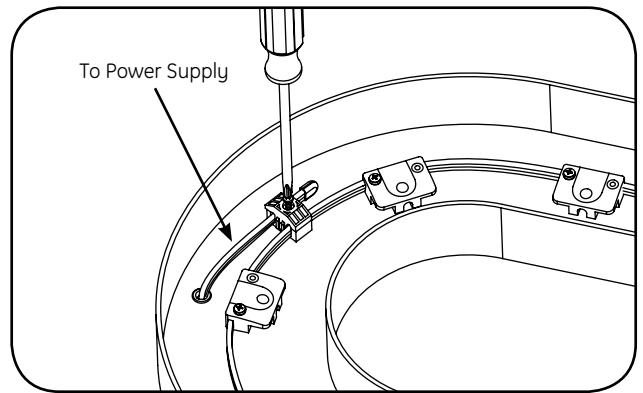

- 4** Place the supply wire in one side of the splice connector and the Tetra Power White XL Strip on the other side, making sure both wires have the same orientation. (The blue stripe of Tetra Power White XL Strip wire to red stripe of Tetra Supply Wire and the white wire of the Tetra Power White XL Strip to the white wire of the Tetra Supply Wire.)

NOTE: All electrical connections should be made within the letter.

Troubleshooting

Symptom	Condition	Solution
All LEDs are off	Overload (Too many feet of strip).	Ensure Tetra Power White XL Strip footage does not exceed the maximum load.
Some LEDs are off	Improper cutting.	Ensure you cut Tetra Power White XL Strip at the "Cut Here" markings on the wire.
LEDs are dim	Too much supply wire.	Refer to Power Supply Installation Instructions .
Some of the letters are not illuminated	Verify wire attachments to the load banks are correct.	Make sure the connections are blue wire to red wire and white to white.
	Check splice connection(s) in the letter and to the supply wire attached to the power supply.	Verify connections are blue-to-red and white-to-white.
All letters are off	Check breaker.	Reset or turn on breaker.
	Short on bank or current is above 5 amps.	Shut down power supply and correct short or reduce Tetra Power White XL Strip footage on output bank; cycle primary power to reset.
Shadows	Shadows appearing around the power supply.	Verify Tetra Power White XL Strip is not installed flush to the power supply. Move Tetra Power White XL Strip 0.5-inch (13mm) away from power supply.

⚠ WARNING!

RISK OF ELECTRIC SHOCK:

- Turn power OFF before inspection, installation or removal.
- Properly ground Tetra Power Supply enclosure.
- Shut off power at fuse box or circuit breaker before installation.



RISK OF FIRE:

- Use only Tetra Supply Wire to make connection from Tetra Power Supply to Tetra Power White XL LED Strip.
- Follow all NEC and local codes.
- Use only approved wire for input connection. Minimum size 1.02mm

Conforms to the following standards:



6180 Halle Drive • Valley View, Ohio 44125-4635 • USA
 P: 216.606.6555 • F: 216.606.6599 • www.led.com • info@led.com

For customer service & technical support, contact:
 1-888-MY-GE-LED (1.888.694.3533)

Lumination, LLC is a subsidiary of the General Electric Company. Tetra is a trademark of Lumination, LLC. The GE brand, logo, and ecomagination are trademarks of the General Electric Company. © 2008 Lumination, LLC. Information provided is subject to change without notice. All values are design or typical values when measured under laboratory conditions.