

Tetra® PowerMAX

LED Lighting System

(GEWHPMS2-65K, GEWWPMS2-30K)

Components

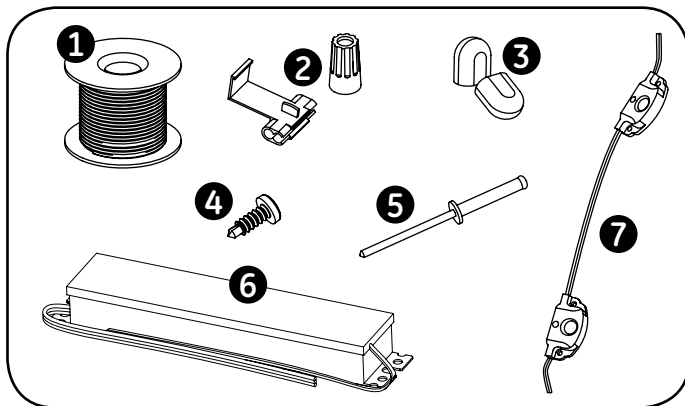

Components required:

- 1 UL approved 18 AWG supply wire (0.82 mm²)
- 2 UL approved 22-14 AWG twist-on wire connectors (0.33 - 2.08 mm²) or 18-14 AWG In-line/IDC connectors (0.82 - 2.08 mm²)
- 3 End caps (GETMEC1)
- 4 #6 or #8 self drilling pan headed screws (M3 or M4)
- 5 1/8-inch rivets (3.175 mm)
- 6 Tetra® 12 Volt Power Supply
- 7 Tetra® PowerMAX LED Modules



BEFORE YOU BEGIN

Read these instructions completely and carefully.

⚠ WARNING/ADVERTISEMENT

Risk of electrical shock. Disconnect power before servicing or installing product.

Risque de choc électrique. Couper l'alimentation avant le dépannage ou avant l'installation du produit.

Save These Instructions

Use only in the manner intended by the manufacturer.
If you have any questions, contact the manufacturer.

Prepare Electrical Wiring



Electrical Requirements

- Do not use in wet locations.
- The grounding and bonding of the LED Driver shall be done in accordance with National Electric Code (NEC) Article 600.
- Follow all National Electric Codes (NEC) and local codes.



imagination at work

Layout Modules

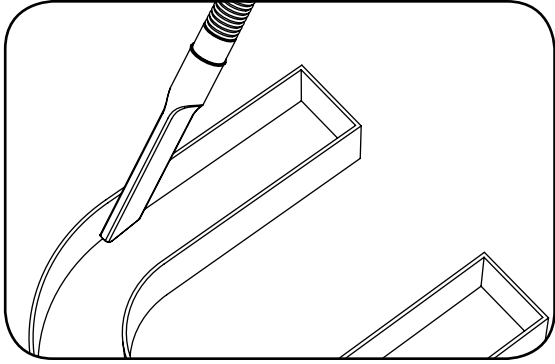

- 1** Clean & remove all debris from the inside of the channel letter before you begin.

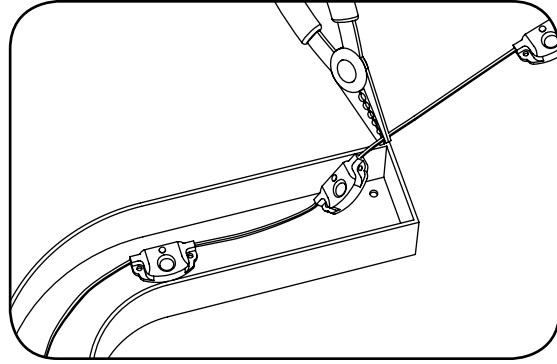

- 2** Measure and cut Tetra® LED strip to the appropriate length for each letter. Cuts can be made between any of the modules.

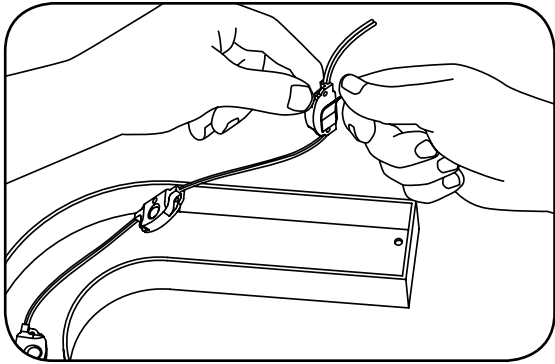

- 3** Remove tape backing and stick LED modules into place. Continue until you have reached the end of the strip.

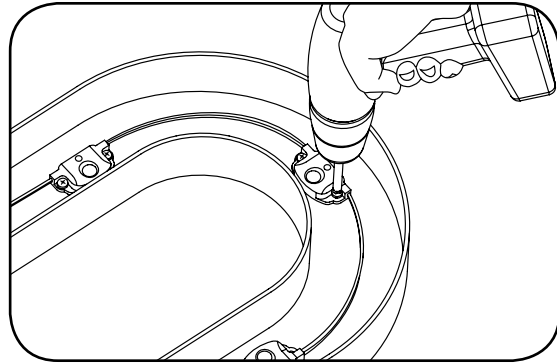

- 4** Must use rivets or screws to secure the LED strip within the channel letter. Use #6 (M3) or #8 (M4) pan headed metal screws or 1/8-inch (3.175 mm) rivets.

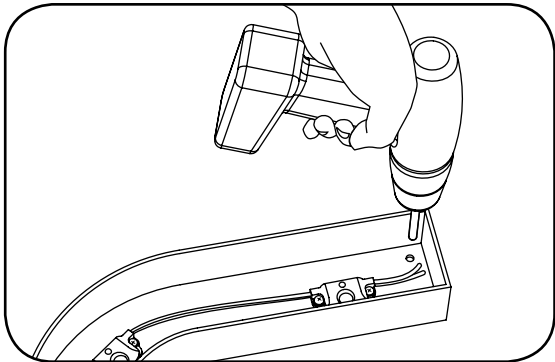

- 5** Drill a 1/4" (6.4 mm) hole near the LED strip and grommet the hole for supply wire access.

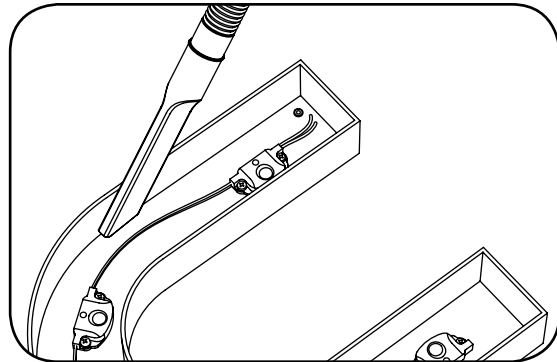

- 6** Clean & remove all debris from the inside of the channel letter. Replace sign face.

NOTE: For halo-lit applications LED modules should be mounted on UL recognized clear acrylic or polycarbonate. The light output from the LED system should be directed back into the sign enclosure. This will allow for uniform backlighting of the sign and will provide simple mounting and protection against moisture.

Electrical Connections

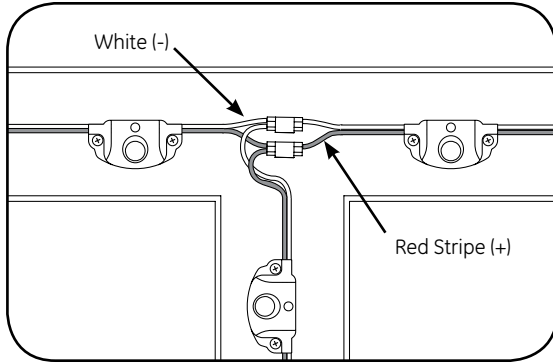

- 1 Connect LED strips using in-line (IDC) connectors or twist-on wire connectors.

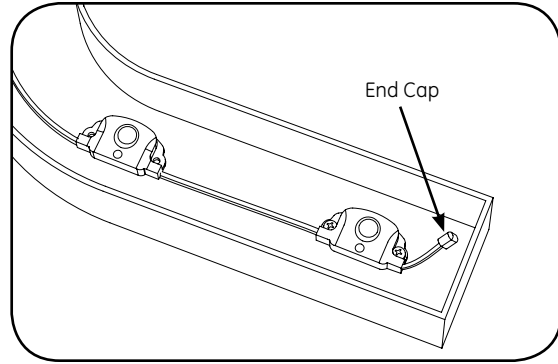

- 2 Must cap all exposed wires with appropriate end caps.

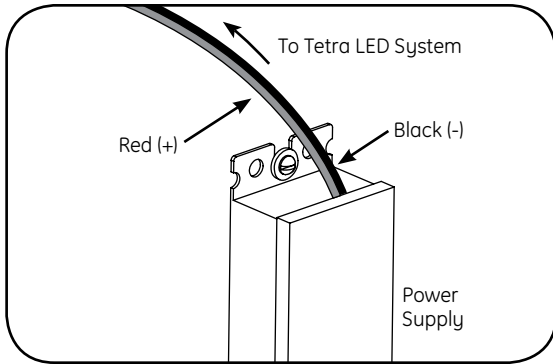

- 3 Run a wire from the Power Supply to each channel letter and connect to the first LED module on the strip.

Must be used with Tetra® 12 Volt Power Supplies.

NOTE: Refer to the **Power Supply Installation Instructions** for electrical requirements, loading and remote mounting information.

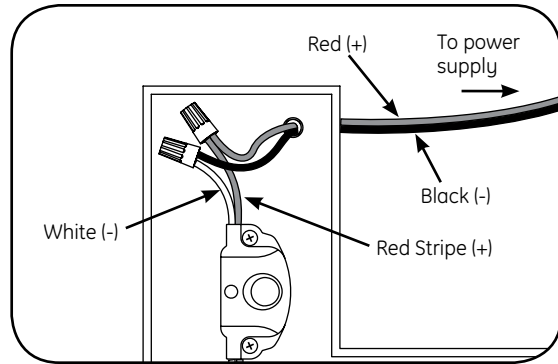

- 4 Connect the red stripe wire (+) of the LED strip to the red wire (+) of the power supply. Connect the white wire (-) of the LED strip to the black wire (-) of the power supply.

NOTE: All electrical connections should be made within the letter.

Troubleshooting

Symptom	Solution
All letters are OFF	<ul style="list-style-type: none">• Check AC input connection and/or check circuit breaker.• Check wire connection(s) at the Tetra® LED System and power supply for improper termination(s) or short circuits. Properly terminate or replace the wire connection(s).• Check that connections are the red stripe wire (+) of the LED strip to the red wire (+) of the power supply and the white wire (-) of the LED strip to the black wire (-) of the power supply.
Some LEDs appear dim	<ul style="list-style-type: none">• Ensure the overall length of the Tetra® LED System does not exceed the maximum load.• Ensure the length of supply wire is equal to or below the recommended remote mounting distance.
Some of the letters are not illuminated	<ul style="list-style-type: none">• Check wire connection(s) at the Tetra® LED System and power supply for improper termination(s) or short circuits. Properly terminate or replace the wire connection(s).• Check that connections are the red stripe wire (+) of the LED strip to the red wire (+) of the power supply and the white wire (-) of the LED strip to the black wire (-) of the power supply.
Shadows	<ul style="list-style-type: none">• Re-route supply wire and secure to the back of the can with silicone. Adjust wire connector orientation so that it does not cover any LEDs.• Adjust LED layout to ensure uniformity of illumination on the face of the letter.

Tips

- Tetra® LED systems are rated for damp location use by UL and should be protected from direct exposure to moisture (i.e., rain & snow).
- For optimal light uniformity in halo-lit applications the Tetra® LED modules should be mounted on UL recognized plastic, and the light output from the Tetra® LED system should be directed back into the sign enclosure. This will allow for uniform backlighting of the sign and will provide simple mounting for the Tetra® LED system.
- When mounting LED modules for halo-lit applications the clear acrylic should be recessed into the body of the sign, or a bead of silicone should be applied to provide a barrier against the elements.
- A best practice for the supply wire at the point at which it is brought into the sign is to have a drip loop on the inside of the letter to keep water from collecting on the Tetra® LED strip.

⚠ WARNING!

RISK OF ELECTRIC SHOCK: <ul style="list-style-type: none">• Turn power OFF before inspection, installation or removal.• Properly ground Tetra® Power Supply enclosure.	RISK OF FIRE: <ul style="list-style-type: none">• Follow all NEC and local codes.• Use only UL approved wire for input/output connections. Minimum size 18 AWG (0.82 mm²)
--	--

Conforms to the following standards:
IP66 rated: separate enclosure required for outdoor use, UL damp location rated



1975 Noble Road • Cleveland, Ohio 44112-6300 • USA
P: 216.266.4800 • F: 216.266.2158 • www.lumination.com • info@lumination.com

For customer service & technical support, contact:
1-888-MY-GE-LED (1.888.694.3533)

Lumination, LLC is a subsidiary of the General Electric Company. Tetra is a trademark of Lumination, LLC. The GE brand, logo, and ecomagination are trademarks of the General Electric Company. © 2010 Lumination, LLC. Information provided is subject to change without notice. All values are design or typical values when measured under laboratory conditions.