

RG6 LED Level Crossing Signal Modules

12 inch (300mm)



Outstanding Reliability

- Self-contained design provides protection against moisture and dust
- Designed for retrofit into existing housings

Excellent Appearance & Visibility

- Robust LED system design enables high luminous intensity over long product life
- Efficient optical system delivers uniform color
- Optional side-lights provide additional visibility

Meets Rigorous Certification & Testing Standards

- Meets AREMA standards
- Transport Canada compliant
- All lamps undergo comprehensive testing in the manufacturing plant
- Lens withstands 100 mph Impact Test¹



imagination at work

RG6 LED Level Crossing Signal Modules

- 12 inch (300mm)

Dimensions in inches. (mm) indicates metric equivalent

Mechanical Outline

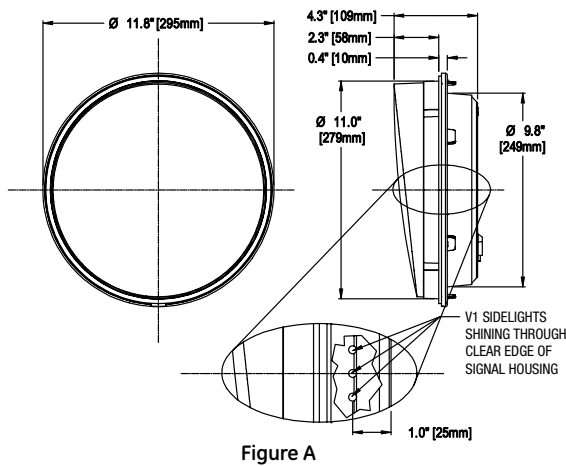

Figure A

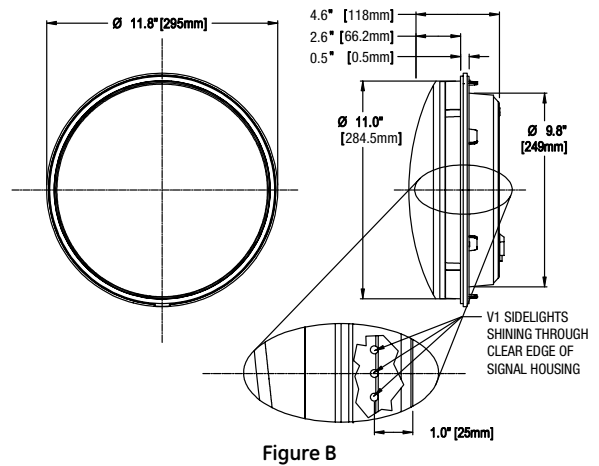

Figure B

Design Compliance

Parameter	Compliance
Environmental Limits	AREMA Part 11.5.1 – Class B
Electronic Noise	AREMA Part 11.5.1 – Class B
Transient Immunity	AREMA Part 11.3.3
Photometric Requirements	Transport Canada AREMA Part 3.2.35
Impact Resistance	100 mph baseball ¹

Operating Specifications

Parameter	Rating
Operating Temperature Range	-40 to +70°C (-40 to +158°F)
Operating Voltage Range	8 to 20V DC 8 to 16V AC (50-60Hz)
Voltage Turn-Off (VTO)	4V
Power Surge	45Vrms for 80ms
Nominal Current Draw	1.5A

Product Information

Model Number	Dominant Wavelength (nm)	Nominal Power (W)	Peak Intensity (cd) ²	Beam Angles (50% of peak intensity)	Field Angles (10% of peak intensity)	Figure
● RG6-RTFB-48B	630	13.2	600	20°H x -7.5°V	45°H x -17.5°V	A
● RG6-RTFB-48BV1 ³	630	12	600	20°H x -7.5°V	45°H x -17.5°V	A
● RG6-RTFB-48BV1-H7	630	12	600	20°H x -7.5°V	45°H x -17.5°V	B

All values are design or typical values when measured under laboratory conditions at T=25°C.

For gasket options, please contact your sales agent.

¹ H7 lamps only. Resists concentric impact from a baseball (NOCSAE DOC 072) projected per NOCSAE DOC 021 Section 5.2 & 12

² This is a minimum, initial value at T = 25°C. Minimum intensity value over 10,000 hours is greater than 400cd, as required by Transport Canada.

³ V1 indicates the sidelight option.

Distributed by:



6180 Halle Drive • Valley View, Ohio 44125-4635, • USA
 P: 216.606.6555 • F: 216.606.6599 •
www.lumination.com • signals@lumination.com

For customer service & technical support, contact:
1-888-MY-GE-LED (1.888.694.3533)

Lumination, LLC is a subsidiary of the General Electric Company. The GE brand and logo are trademarks of the General Electric Company.
 © 2009 Lumination, LLC. Information provided is subject to change without notice. All values are design or typical values when measured under laboratory conditions.