

# IMMERSION™

LED Display Lighting

Refrigerated Vertical Cases  
RV30 Series

## PS1700 LED Driver

GE-PS1700NCMUL-SY



### BEFORE YOU BEGIN

Read these instructions completely and carefully.

#### ⚠ WARNING / AVERTISSEMENT

**Risk of electrical shock.** Disconnect power before servicing or installing product. / **Risque de choc électrique.** Couper l'alimentation avant le dépannage ou avant l'installation du produit.

#### ⚠ CAUTION / ATTENTION

**Risk of injury.** While performing installations described, gloves, safety glasses or goggles should be worn. / **Risque de blessure.** Lors de l'exécution des installations décrites, des gants, des lunettes de sécurité ou des lunettes de protection doivent être portées.

#### PREPARE ELECTRICAL WIRING



##### *Electrical Requirements*

- The power supply must be supplied with 100-240 VAC, 50/60 Hz., and connected to an individual properly grounded branch circuit, protected by a 15 or 20 ampere circuit breaker or time delay fuse.
- Wiring must be 2 wire with ground and rated for 75°C (176°F).



##### *Grounding Instructions—Cable Direct*

- This lighting system must be connected to a grounded metal, permanent wiring system, or an equipment grounding conductor must be run with the circuit conductors and be connected to the equipment grounding terminal or lead on the LED Light.

- A. Use this unit only in the manner intended by the manufacturer. If you have any questions, contact the manufacturer.
- B. Before servicing or cleaning unit, switch power off at the service panel and follow appropriate lock out / tag out safety procedures.

#### FOR YOUR SAFETY

**Read and observe all CAUTIONS and WARNINGS shown throughout these instructions.**

- Installation to be performed by factory trained service personnel only.
- For use inside a commercial refrigeration case with packaged foods only.

Conforms to the following standards:



**NOTE:** This device complies with Part 15 of the FCC Rules. Operation is subject to the following two conditions: (1) this device may not cause harmful interference, and (2) this device must accept any interference received, including interference that may cause undesired operation.

This Class [A] RFLD complies with the Canadian standard ICES-005. Ce DEFR de la classe [A] est conforme à la NMB-005 du Canada



imagination at work

# 1<sup>A</sup>

## Connect LED Driver - Input

- Place LED Driver in the mullion or raceway for ease of wire connection.
- Make input (AC) connections using one of the two options below:

### OPTION 1 - USING 3-WAY CONNECTOR

Connect the original Line and neutral wires (or Line 1 and Line 2 wires for 240 nominal VAC) to the 3-way connector for the LED Driver input wires using the appropriate mating connector (Molex P/N 39-01-4030). Ensure that the connector cavities are correctly populated per the schematics on the LED Driver. (A)

### OPTION 2 - USING TWIST-ON WIRE CONNECTOR

Remove the 3-way connector from the LED Driver by cutting the wires near the connector and strip the input wires. Using the appropriate schematics below, connect the original Line and neutral wires (or Line 1 and Line 2 wires for 240 nominal VAC) to the LED Driver leads using wire connectors or other connection method approved for low temperature usage and stranded cable. (A)

- The LED Driver and LED Light are required to be reliably bonded to the protective ground conductor. Attach the supplied green/yellow ground wire from the LED Light to a grounded metal portion of the door frame. (B)

# 1<sup>B</sup>

## Connect LED Driver - Output

- Make output (DC) connections using one of the two options below:

### OPTION 1 - USING 4-WAY CONNECTOR

Connect the LED Driver output leads to the LED Light leads using the appropriate mating connector (Molex P/N 39-01-4046). Terminals installed should be crimped using approved tooling and process per Molex specifications. Ensure that the connector cavities are correctly populated per the schematics below. (C)

### OPTION 2 - USING TWIST-ON WIRE CONNECTORS

Remove the 4-way connector from the LED Driver by cutting the wires near the connector and strip the output leads. Using the appropriate schematics below, connect the LED Driver output leads to the LED Light leads using wire connectors or other connection method approved for low temperature usage and stranded cable. (C)

### ⚠ WARNING / AVERTISSEMENT

**Risk of electrical shock.** Ensure that all connection points are sealed for damp location using the appropriate method per the NEC or local electrical code. / **Risque de choc électrique.** S'assurer que les points de raccordements sont scellés pour emplacement humide en employant une méthode permise par le NEC ou par le code électrique local.

### One End Set (R & L) LED Lights

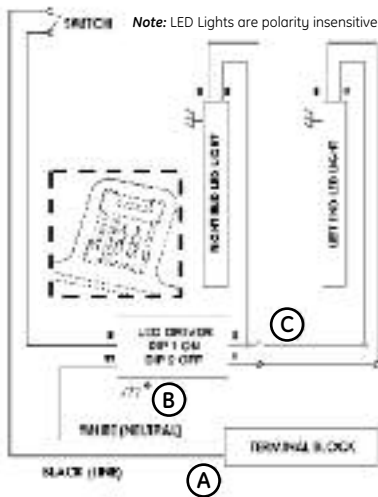

### Two Center LED Lights

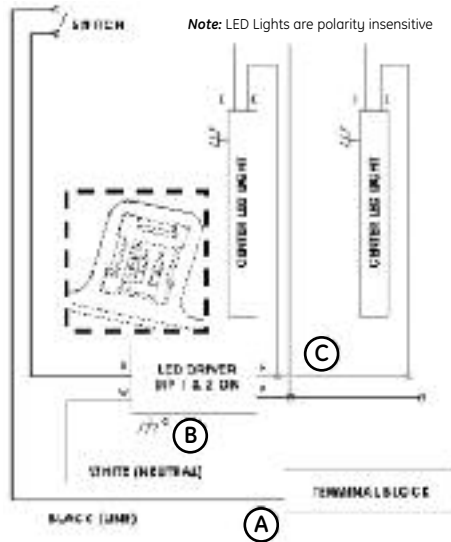

### One Center LED Light

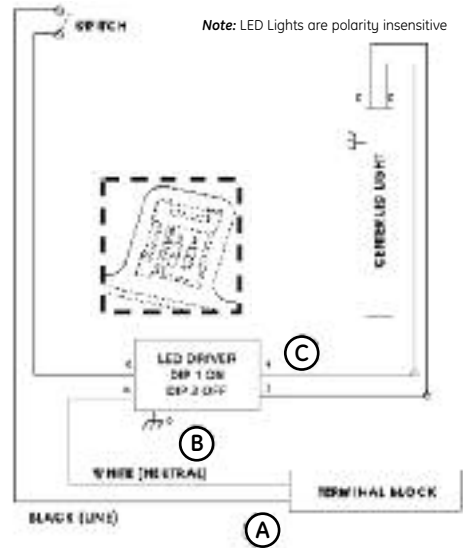

### One End Set (Right and Left) & One Center LED Light

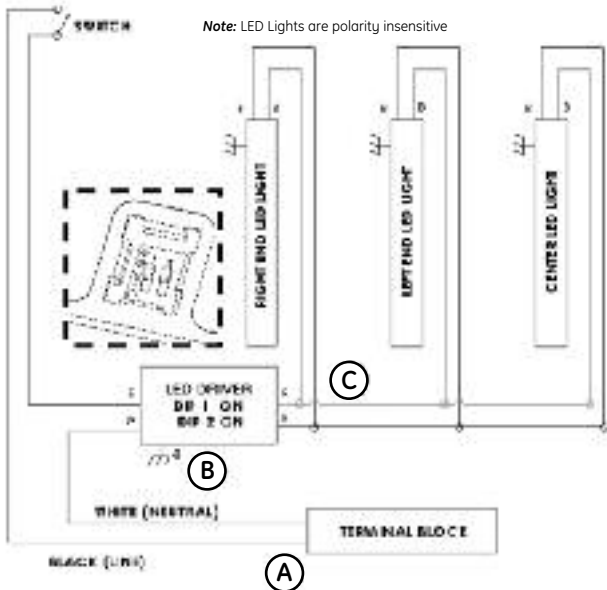

### One End LED Light (Right or Left) & One Center LED Light

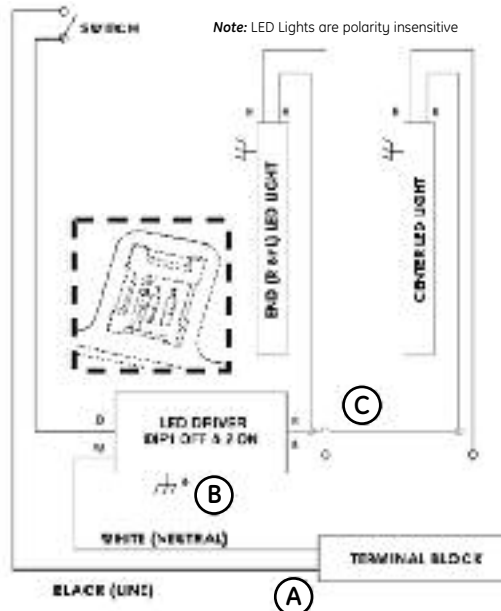

### Wire Cavities

#### 39-01-4030 (AC)

- Cavity 1 - Line 1
- Cavity 2 - Earth Ground
- Cavity 3 - Neutral (or Line 2)

#### 39-01-4046 (DC)

- Cavity 1 - Output DC +
- Cavity 2 - Output DC -
- Cavity 3 - Empty
- Cavity 4 - Empty

## 2<sup>A</sup> LED Driver Dip Switch Settings

### LED Driver

Orientation:  
Red & black wire outputs on right

**DIP SWITCH**

1	2	LED Light Configuration
ON	ON	1 Center and 2 Ends
OFF	ON	1 Center and 1 End
ON	OFF	1 Center OR 2 Ends
OFF	OFF	Test Mode

**On Dip Switch Orientation**

**H** = LED Driver Set to High Mode: 1 and 2 "ON"

**M** = LED Driver Set to Medium Mode: 1 "OFF" and 2 "ON"

**L** = LED Driver Set to Low Mode: 1 "ON" and 2 "OFF"

NOTE: Test Mode = 1 "OFF" and 2 "OFF" DO NOT USE.

## 2<sup>B</sup> Case Configuration Options

Case Type	6-Door					
LED Driver Configuration	Option 1: Reduces materials 			Option 2: Reduces labor 		
Case Configuration						
# Center LED Lights	5					
# End LED Light Sets	1 Set (1 Left & 1 Right)					
# LED Drivers	3		4			
# Accessory Parts	Center Mounting Clips - 10	End Mounting Clips - 4	Wire Covers - 7			

Case Type	5-Door					
LED Driver Configuration	Option 1: Reduces materials 			Option 2: Reduces labor 		
Case Configuration						
# Center LED Lights	4					
# End LED Light Sets	1 Set (1 Left & 1 Right)					
# LED Drivers	3		3			
# Accessory Parts	Center Mounting Clips - 8	End Mounting Clips - 4	Wire Covers - 6			

# 2<sup>B</sup>

## Case Configuration Options - continued

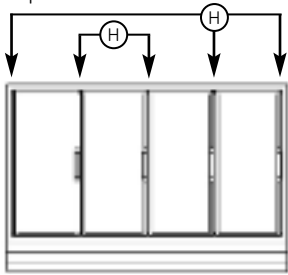
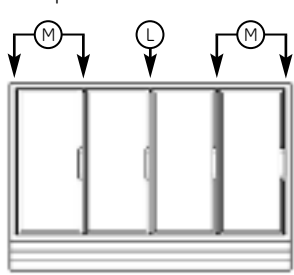
Case Type	4-Door		
LED Driver Configuration	Option 1: Reduces materials 		Option 2: Reduces labor 
Case Configuration			
# Center LED Lights	3		
# End LED Light Sets	1 Set (1 Left & 1 Right)		
# LED Drivers	2		3
# Accessory Parts	Center Mounting Clips - 6	End Mounting Clips - 4	Wire Covers - 5

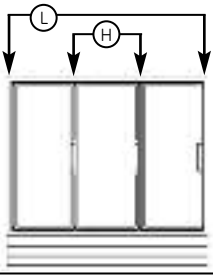
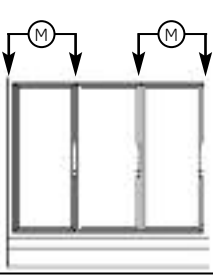
Case Type	3-Door		
LED Driver Configuration	Option 1: Reduces materials 		Option 2: Reduces labor 
Case Configuration			
# Center LED Lights	2		
# End LED Light Sets	1 Set (1 Left & 1 Right)		
# LED Drivers	2		2
# Accessory Parts	Center Mounting Clips - 4	End Mounting Clips - 4	Wire Covers - 4

Case Type	2-Door														
LED Driver Configuration															
Case Configuration			<table border="1"> <tr> <td># Center LED Lights</td> <td>1</td> </tr> <tr> <td># End LED Light Sets</td> <td>1 Set (1 Left &amp; 1 Right)</td> </tr> <tr> <td># LED Drivers</td> <td>1</td> </tr> <tr> <td># Center Mounting Clips</td> <td>2</td> </tr> <tr> <td># End Mounting Clips</td> <td>4</td> </tr> <tr> <td># Wire Covers</td> <td>3</td> </tr> </table>	# Center LED Lights	1	# End LED Light Sets	1 Set (1 Left & 1 Right)	# LED Drivers	1	# Center Mounting Clips	2	# End Mounting Clips	4	# Wire Covers	3
# Center LED Lights	1														
# End LED Light Sets	1 Set (1 Left & 1 Right)														
# LED Drivers	1														
# Center Mounting Clips	2														
# End Mounting Clips	4														
# Wire Covers	3														



6180 Halle Drive • Valley View, Ohio 44125-4635 • USA  
 P: 216.606.6555 • F: 216.606.6599 • lumination.com • info@lumination.com

For customer service & technical support,  
 contact: **1-888-MY-GE-LED** (1.888.694.3533)

Lumination, LLC is a subsidiary of the General Electric Company. Immersion is a trademark of Lumination, LLC. The GE brand and logo are trademarks of the General Electric Company. © 2009 Lumination, LLC. Information provided is subject to change without notice. All values are design or typical values when measured under laboratory conditions.