

# IMMERSION™

LED Display Lighting

Refrigerated Vertical Cases  
RV30 Series

## End Mullion Lights

**60-inch:** GE-LT306035EDL, GE-LT306035EDR, GE-LT306041EDL,  
GE-LT306041EDR, GE-LT306050EDL & GE-LT306050EDR

**70-inch:** GE-LT307035EDL, GE-LT307035EDR, GE-LT307041EDL,  
GE-LT307041EDR, GE-LT307050EDL & GE-LT307050EDR



## BEFORE YOU BEGIN

Read these instructions completely and carefully.

### ⚠ WARNING / AVERTISSEMENT

**Risk of electrical shock.** Disconnect power before servicing or installing product. / **Risque de choc électrique.** Couper l'alimentation avant le dépannage ou avant l'installation du produit.

### ⚠ CAUTION / ATTENTION

**Risk of injury.** While performing installations described, gloves, safety glasses or goggles should be worn. / **Risque de blessure.** Lors de l'exécution des installations décrites, des gants, des lunettes de sécurité ou des lunettes de protection doivent être portées.

## PREPARE ELECTRICAL WIRING



### Electrical Requirements

- The power supply must be supplied with 100-240 VAC, 50/60 Hz and connected to an individual properly grounded branch circuit, protected by a 15 or 20 ampere circuit breaker or time delay fuse.
- Wiring must be 2 wire with ground and rated for 75°C (176°F).



### Grounding Instructions—Cable Direct

- This lighting system must be connected to a grounded metal, permanent wiring system, or an equipment grounding conductor must be run with the circuit conductors and be connected to the equipment grounding terminal or lead on the LED Light.

- A. Use this unit only in the manner intended by the manufacturer. If you have any questions, contact the manufacturer.
- B. Before servicing or cleaning unit, switch power off at the service panel and follow appropriate lock out / tag out safety procedures.

## FOR YOUR SAFETY

Read and observe all CAUTIONS and WARNINGS shown throughout these instructions.

- Installation to be performed by factory trained service personnel only.
- For use inside a commercial refrigeration case with packaged foods only.

## LED DRIVER COMPATIBILITY

This system is compatible with the **GE-PS1700NCMUL-SY LED Driver**. Please refer to the separate LED driver installation guide for appropriate wiring connections.



## 1<sup>A</sup> Prepare for Installation of End Mounting Clips

- Measure 1 3/32-inches (28 mm) from the edge of the mullion nearest the door, and mark a vertical line near the top and bottom of the frame mullion.
- Prepare for the top mounting clip. Mark a horizontal line a minimum 2 1/8-inches (54 mm) from the top of the door opening, and another horizontal line 3/8-inches (10 mm) below this line.
- Prepare the bottom mounting clip. For 60-inch LED Lights, mark a horizontal line 58 3/32-inches (1476 mm) beneath the first line drawn for the top mounting clip. [For 70-inch LED Lights, increase length to 68 15/32-inches (1739 mm).] Then mark another line 3/8-inches (10 mm) below this line.
- Center the center punch directly at the intersection of the horizontal lines (4 total) and the vertical line (top and bottom) and establish a dimple.
- Use power drill and 7/64-inch drill bit to drill (4) holes at the intersection of the vertical center line and the horizontal lines.
- **Repeat these steps for the mullion on the other end of the case.**

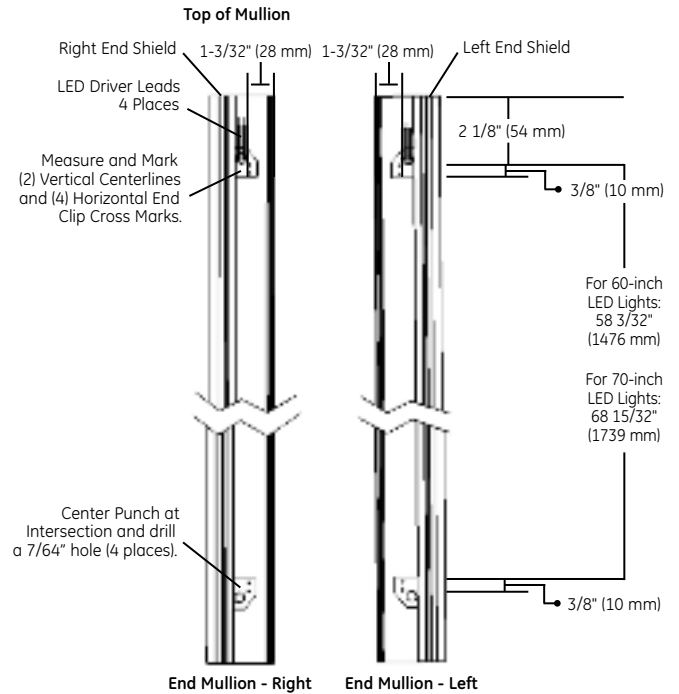

### ⚠ CAUTION / ATTENTION

**Risk of damage to unit.** Prior to drilling make sure that there are no existing components inside the mullion in the areas marked off for the designated holes. / **Risque d'endommager l'unité.** Avant de percer, faire en sorte qu'il n'y ait pas de composantes dans la cloison dans les zones délimitées et identifiées pour le perçage.

## 1<sup>B</sup> Identify End LED Light - Right from Left

- Verify LEDs are directed towards the center of the case before installing.

**NOTE:** Installing the LED Light on the wrong side will result in very low light level inside the refrigerated case.

## 1<sup>C</sup> Identify End Mounting Clips Right from Left

- Each LED Light requires one ED1 and one ED2 clip for mounting.

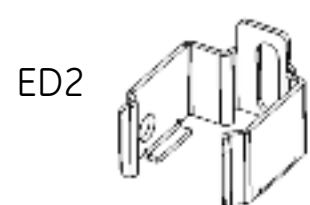

## 2

### Install End Mounting Clips

- Place proper End Mounting Clip against the face of the mullion near the two holes drilled at the top with mounting slots upward.  
**NOTE:** Refer to proper End Mounting Clip orientation depicted in Step 1.
- Insert a #6-32 x 1/4-inch sheet metal screw into the slot on the End Mounting Clip, and into the first hole that was drilled in the end mullion.  
**NOTE:** The hole in the side of the clip faces toward the center of the case.
- Use a screwdriver to start threading the screw into the drilled hole.
- Repeat for the second screw, and for the bottom End Mounting Clip. A total of (4) screws and (2) End Mounting Clips should be installed.
- Repeat these steps for the mullion on the other end of the case. Make sure the orientation is correct and proper clip is used.  
**NOTE:** The bottom End Mounting Clip should be installed with the mounting slots downward.

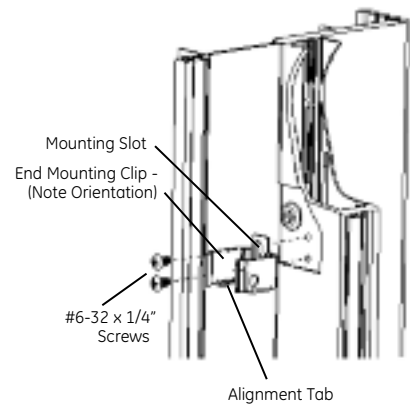

**NOTE:** The End Mounting Clips should be level with the horizontal lines marked in the previous step. Loosen both screws to readjust the End Mounting Clips if necessary. Retighten screws before proceeding to the next step.

## 3

### Install End LED Lights

- Move/slide the End LED Light up or down to center between the top and bottom End Mounting Clips prior to snapping it into the clips.
- Insert the End LED Light End Cap into mounting clip as shown.  
**NOTE:** Refer to proper End Mounting Clip orientation depicted in Step 1.
- Make sure the bottom tabs on the clip slide into the slots on the End Cap and that the ends of the clip snap in place on the End Cap.
- Repeat these steps for the mullion on the other end of the case. Make sure orientation is correct.  
**NOTE:** Refer to proper End Mounting Clip orientation depicted in Step 1.  
**NOTE:** It may be required to loosen the screws holding the clips to properly position the light bar and re-tighten them after snapping light bar in place.
- Refer to the Removal Instructions in Step 6 to remove the End LED Light from the End Mounting Clips if repositioning is required.

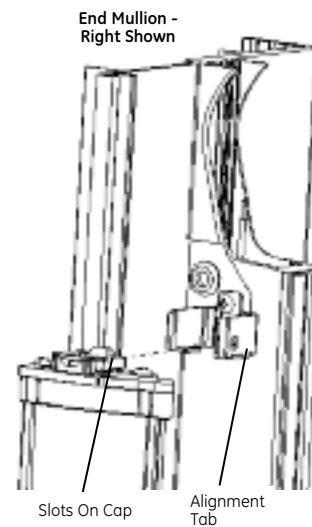

## 4

### Electrical Connections

- Connect LED Lights to the **GE-PS1700NCMUL-SY LED Driver**.  
**NOTE:** Please refer to the **GE-PS1700NCMUL-SY LED Driver Installation Guide** for the different LED Light Wiring Configurations.
- Connect one black wire from the End LED Light to an 18 AWG (0.823 mm<sup>2</sup>) LED Driver wire. Connect the remaining black wire from the End LED Light to the other 18 AWG (0.823 mm<sup>2</sup>) wire from the LED Driver. Use a tap type connector (Grainger part # 1A074 T-Tap Connector) or other approved connector for low temperature usage and 18 AWG (0.823 mm<sup>2</sup>) wire. **(A)**  
**NOTE:** Black wires from LED Light are NOT polarity sensitive.
- Attach the supplied green/yellow ground wire from the LED Light to a grounded metal portion of the door frame. **(B)**
- Remove protective film from lens. (C)**  
**NOTE:** Failure to remove film will result in very low light output inside the refrigerated case.
- Repeat these steps for the mullion on the other end of the case.

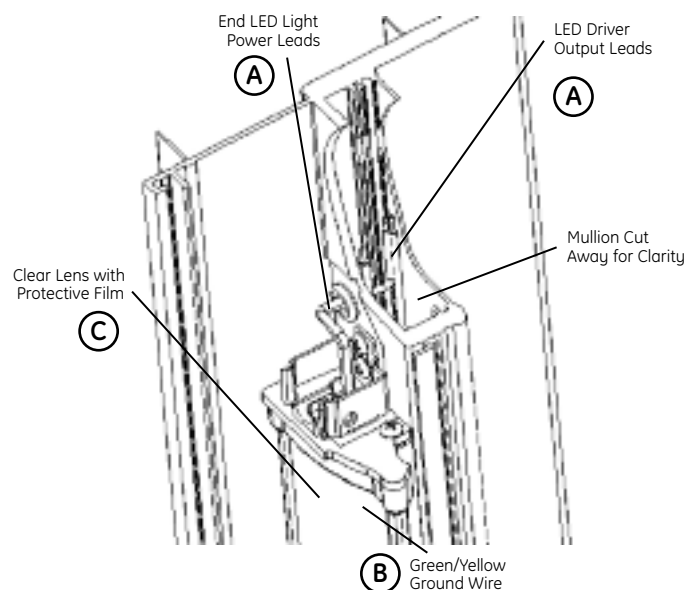

#### ⚠ WARNING / AVERTISSEMENT

**Risk of fire, electrical shock or injury.** Ensure that all connection points are sealed for damp location using the appropriate method per the NEC or local electrical code. **Risk of electrical shock.** Ensure proper grounding of the lighting system through a ground wire. / **Risque d'incendie, d'électrocution ou de blessure.** Veiller à ce que tout les branchements soient protégés ou scellés contre les emplacements humides en utilisant la méthode appropriée selon le NEC ou le code électrique local. **Risque de choc électrique.** Veiller à fournir une mise à la terre adéquate pour le système d'éclairage par l'intermédiaire d'un fil de mise à la terre.

## 5 Attach Covers to End Cap

- Tuck wires underneath Low Profile Cover before placing it over the End Cap and Mounting Clip.
- Attach Low Profile Cover to LED Light End Cap by installing a #6-19 x 3/8-inch plastic tapping screw (provided) through the hole in the End Cap and Mounting Clip. **(A)**
- **NOTE:** Do not overtighten.
- Install a second plastic tapping screw on opposite end of lightbar to secure End Cap to Mounting Clip.
- Repeat these steps for the mullion on the other end of the case.

### ⚠ CAUTION / ATTENTION

**Risk of electrical shock.** Plastic cover is needed to protect electrical wires from tampering and accidental contact. / **Risque de choc électrique.** Le couvercle en plastique est requis pour assurer une protection adéquate contre l'accès aux fils et les contacts accidentels.

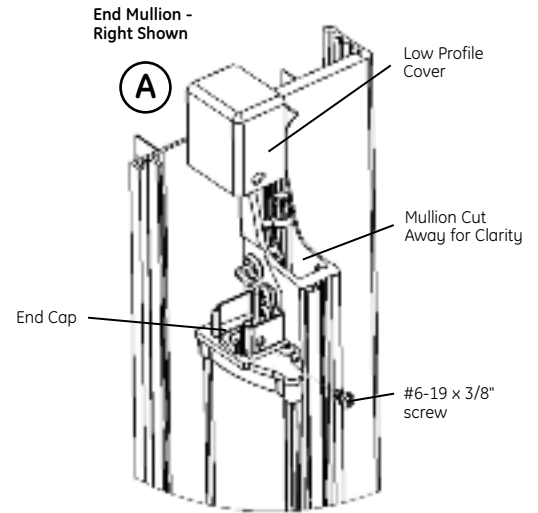

## 6 Removal Instructions

- Using a phillips screwdriver remove screw and cover from wire end of LED Light and screw from opposite end of LED Light.
- With a free hand grab the End LED Light and pull straight forward to remove from the Mounting Clips.
- Electrical connections can be removed to facilitate the removal of the LED Light.
- Repeat these steps for the mullion on the other end of the case.

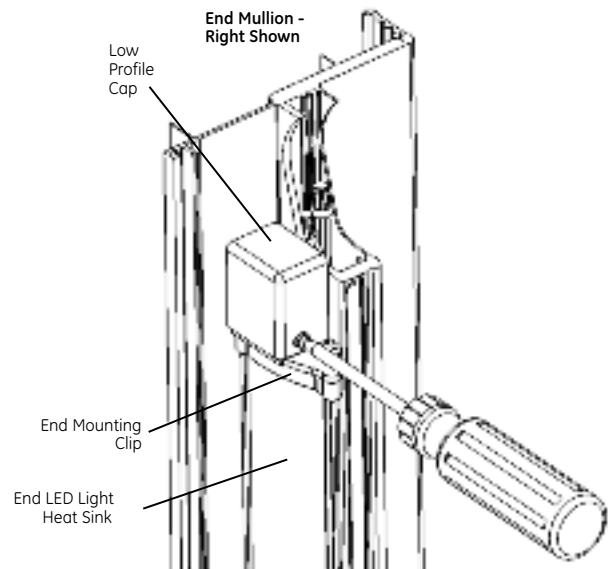

## 7 LED Refrigerated Display Lights – Cleaning Instructions

- The outer lens and the heat sink should be cleaned periodically with a mild liquid dish detergent.
- Do not use chemical cleaners to clean the lens.
- Keep the outside clean. Wipe with a clean cloth lightly dampened with mild liquid dish detergent. Dry with a clean, soft cloth.
- Do not wipe the lens with a soiled dish cloth or wet towel. These may leave a residue that can damage the finish.
- Do not use scouring pads, powdered cleaners, bleach or cleaners containing bleach because these products can scratch and damage the finish.



6180 Halle Drive • Valley View, Ohio 44125-4635 • USA  
P: 216.606.6555 • F: 216.606.6599 • [www.lumination.com](http://www.lumination.com) • [info@lumination.com](mailto:info@lumination.com)

For customer service & technical support,  
contact: **1-888-MY-GE-LED** (1.888.694.3533)

Lumination, LLC is a subsidiary of the General Electric Company. Immersion is a trademark of Lumination, LLC. The GE brand and logo are trademarks of the General Electric Company. © 2009 Lumination, LLC. Information provided is subject to change without notice. All values are design or typical values when measured under laboratory conditions.