

IMMERSION™

LED Display Lighting

Refrigerated Vertical Cases
RV30 Series

Center Mullion LED Lights

30-inch: GE-LT303050CTR & GE-LT303041CTR



BEFORE YOU BEGIN

Read these instructions completely and carefully.

⚠ WARNING / AVERTISSEMENT

Risk of electrical shock. Disconnect power before servicing or installing product. / **Risque de choc électrique.** Couper l'alimentation avant le dépannage ou avant l'installation du produit.

⚠ CAUTION / ATTENTION

Risk of injury. While performing installations described, gloves, safety glasses or goggles should be worn. / **Risque de blessure.** Lors de l'exécution des installations décrites, des gants, des lunettes de sécurité ou des lunettes de protection doivent être portées.

PREPARE ELECTRICAL WIRING



Electrical Requirements

- The power supply must be supplied with 100-240 VAC, 50/60 Hz and connected to an individual properly grounded branch circuit, protected by an appropriately sized ampere circuit breaker or time delay fuse.
- Wiring must be 2 wire with ground and rated for 75°C (176°F).



Grounding Instructions—Cable Direct

- This lighting system must be connected to a grounded metal, permanent wiring system, or an equipment grounding conductor must be run with the circuit conductors and be connected to the equipment grounding terminal.

- A. Use this unit only in the manner intended by the manufacturer. If you have any questions, contact the manufacturer.
- B. Before servicing or cleaning unit, switch power off at the service panel and follow appropriate lock out / tag out safety procedures.

FOR YOUR SAFETY

Read and observe all CAUTIONS and WARNINGS shown throughout these instructions.

- Installation to be performed by factory trained service personnel only.
- For use inside a commercial refrigeration case with packaged foods only.

LED DRIVER COMPATIBILITY

This system is compatible with the **GE080/G/V24T1-A LED Driver**. Please refer to the separate LED Driver Installation Guide for appropriate wiring connections.



imagination at work

1 Prepare for Installation of Center Mounting Clips

- Measure the total width of the mullion, and mark a vertical line half the total width near the top and bottom of the mullion.
- Prepare for the top mounting clip. Mark a horizontal line a minimum 2 1/8-inches (54 mm) from the top of the mullion, and another horizontal line 3/8-inch (10 mm) below this line.
- Prepare the bottom mounting clip. Mark a horizontal line 27 7/10-inches (704 mm) beneath the first line drawn for the top mounting clip. Then mark another line 3/8-inches (10 mm) below this line.
- Center the center punch directly at the intersection of the horizontal lines (4 total) and the vertical line (top and bottom) and establish a dimple.
- Use power drill and 7/64-inch drill bit to drill (4) holes at the intersection of the vertical center line and the horizontal lines.

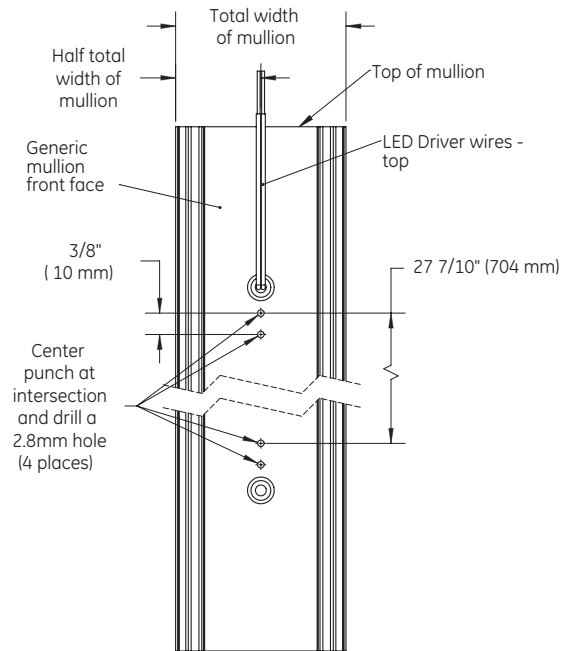

⚠ CAUTION / ATTENTION

Risk of damage to unit. Prior to drilling make sure that there are no existing components inside the mullion in the areas marked off for the designated holes. / **Risque d'endommager l'unité.** Avant de percer, faire en sorte qu'il n'y ait pas de composantes dans la cloison dans les zones délimitées et identifiées pour le perçage.

2 Install Center Mounting Clips

- Place a Center Mounting Clip against the face of the mullion near the two holes drilled at the top with mounting slots upward.
- Insert a #6-32 x 1/4-inch sheet metal screw into the top slot of the Center Mounting Clip and into the first hole that was drilled in the center mullion.
- Use a screwdriver to start threading the screw into the drilled hole.
- Repeat for the second screw, and for the lower Center Mounting Clip. A total of (4) screws and (2) Center Mounting Clips should be installed.

NOTE: The lower Center Mounting Clip should be installed with the alignment tabs upward.

NOTE: The Center Mounting Clips should be level with the horizontal lines marked in the previous step. Loosen both screws to readjust the Center Mounting Clips if necessary. Retighten screws before proceeding to the next step.

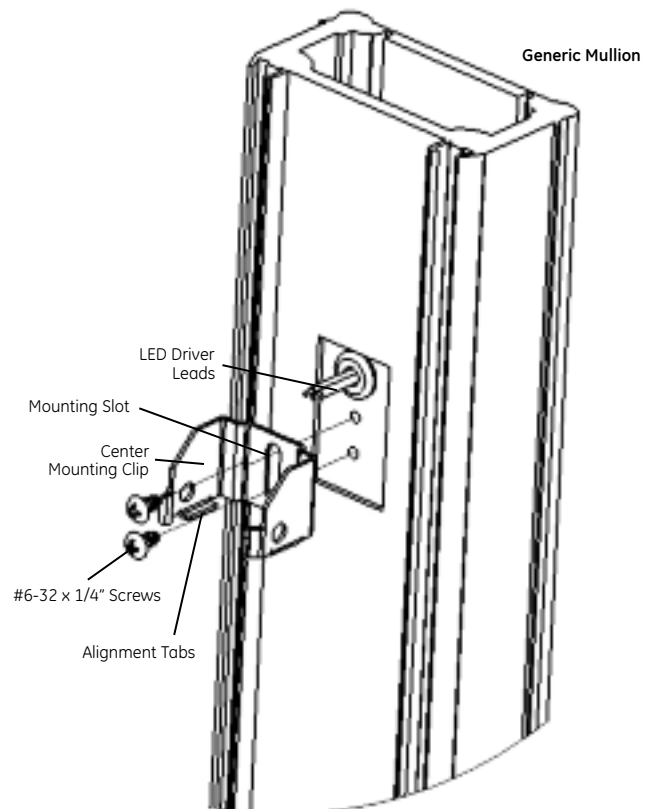

3 Install Center LED Light

- Move/slide the Center LED Light up or down to center between the top and bottom Center Mounting Clips prior to snapping it into the clips.
- Snap the Center LED Light onto the top and bottom Center Mounting Clips.
- Make sure the tabs on the clip snap in place on the Center LED Light.
- Refer to the Removal Instructions in Step 6 to remove the Center LED Light from the Center Mounting Clips if repositioning is required.

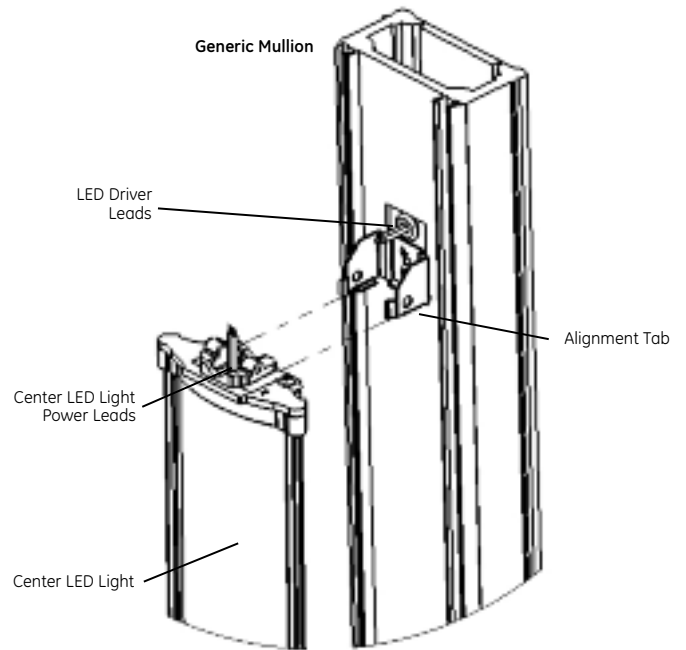

4 Electrical Connections

- Connect LED Lights to the **GE080/G/V24T1-A LED Driver**. A maximum load of up to 2 End LED Lights and 5 Center LED Lights -OR- a total of 6 Center LED Lights with zero End LED Lights can be connected to one LED Driver.

NOTE: Please refer to the **GE080/G/V24T1-A LED Driver Installation Guide** for complete installation instructions.

- Connect one black wire from the Center LED Light to an 18 AWG (0.823 mm²) wire from the LED Driver. Connect the remaining black wire from the Center LED Light to another 18 AWG (0.823 mm²) wire from the LED Driver. Use a tap type connector (Grainger part # 1A074 T-Tap Connector) or other approved connector for low temperature usage and 18 AWG (0.823 mm²) wire. **(A)**

NOTE: Black wires from LED Light are NOT polarity sensitive.

- **Remove protective film from lens. (B)**

NOTE: Failure to remove film will result in very low light output inside the refrigerated case.

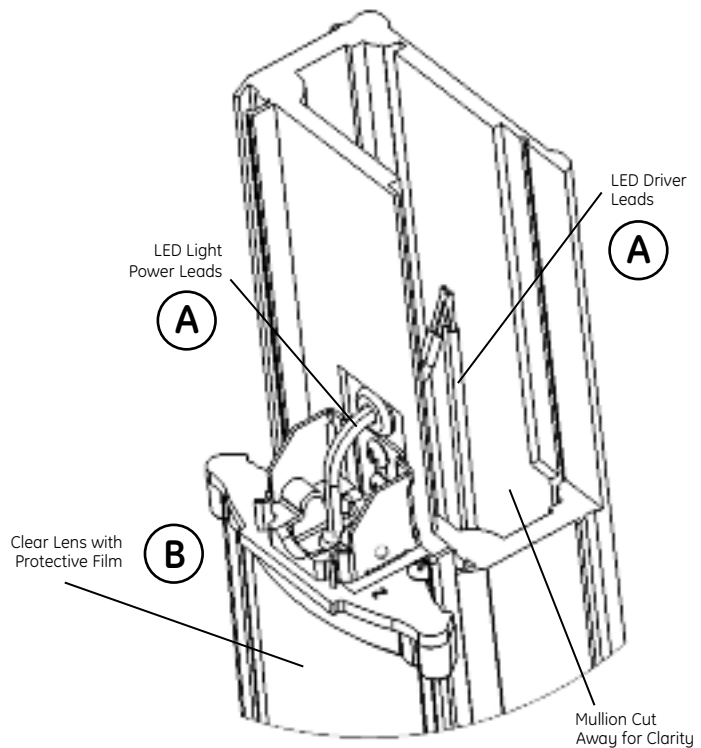

⚠ WARNING / AVERTISSEMENT

Risk of fire, electrical shock or injury. Ensure that all connection points are sealed for damp location using the appropriate method per the NEC or local electrical code. **Risk of electrical shock.** Ensure proper grounding of the lighting system through a ground wire. / **Risque d'incendie, d'électrocution ou de blessure.** Veiller à ce que tous les branchements soient protégés ou scellés contre les emplacements humides en utilisant la méthode appropriée selon le NEC ou le code électrique local. **Risque de choc électrique.** Veiller à fournir une mise à la terre adéquate pour le système d'éclairage par l'intermédiaire d'un fil de mise à la terre.

5 Attach Covers to End Cap

- Tuck wires underneath Low Profile Cover before installing it onto the End Cap.
- Attach Low Profile Cover to LED Light End Cap by inserting a #6-19 x 3/8-inch plastic tapped screw (provided) through the holes in Covers and Mounting Clips. **(A)**
- Install plastic tapping screws on opposite end of the LED Light to secure the End Cap to the Mounting Clip.

⚠ CAUTION / ATTENTION

Risk of electrical shock. Plastic cover is needed to protect electrical wires from tampering and accidental contact. / **Risque de choc électrique.** Le couvercle en plastique est requis pour assurer une protection adéquate contre l'accès aux fils et les contacts accidentels.

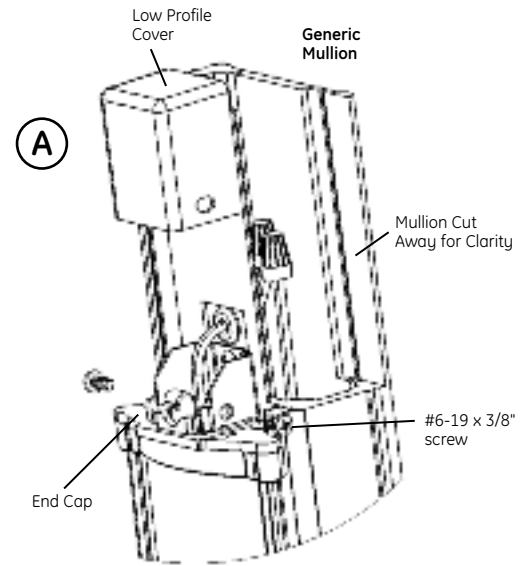

6 Removal Instructions

- Using a phillips screwdriver remove screws and Low Profile Cover from top of LED Light and screws from the opposite end.
- With a free hand grab the Center LED Light and pull the LED Light straight off the Mounting Clip.
- Repeat process for the remaining Center Mounting Clip making sure you support the Center LED Light with your free hand.
- Electrical connections can be removed to facilitate the removal of the Center LED Light from the refrigerated case.

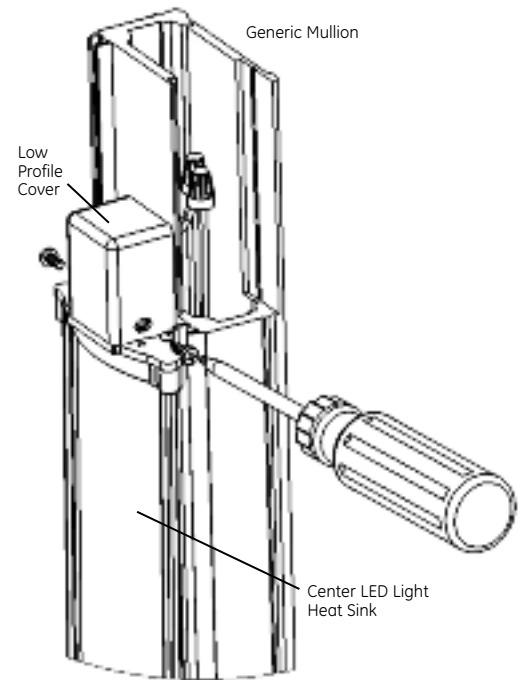

7 LED Refrigerated Display Light – Cleaning Instructions

- The outer lens and the heat sink should be cleaned periodically with a mild liquid dish detergent.
- Do not use chemical cleaners to clean the lens.
- Keep the outside clean. Wipe with a clean cloth lightly dampened with mild liquid dish detergent. Dry with a clean, soft cloth.
- Do not wipe the lens with a soiled dish cloth or wet towel. These may leave a residue that can damage the finish.
- Do not use scouring pads, powdered cleaners, bleach or cleaners containing bleach because these products can scratch and damage the finish.



6180 Halle Drive • Valley View, Ohio 44125-4635 • USA
 P: 216.606.6555 • F: 216.606.6599 • www.lumination.com • info@lumination.com

For customer service & technical support,
 contact: **1-888-MY-GE-LED** (1.888.694.3533)

Lumination, LLC is a subsidiary of the General Electric Company. Immersion is a trademark of Lumination, LLC. The GE brand and logo are trademarks of the General Electric Company. © 2009 Lumination, LLC. Information provided is subject to change without notice. All values are design or typical values when measured under laboratory conditions.